

# BH SERIES



# Royal

## BEVEL HEADED PUNCHES

### TOOL STEEL, (TS)

(OHTS), 58-60 RC, HEADS DRAWN

### HIGH SPEED STEEL (HSS)

M-2, 60-63 RC

Used by tool, die, stamping, and mold manufacturers as perforators, punches, knock-out pins, gauge pins, ejectors and core pins.

Special lengths can be made to order with prompt delivery. Please refer to the "Modify Length" column in the price table below.

When closer tolerance and better wear resistance is desired, please refer to Type RQA found on page 2. RQA perforators/core pin blanks are form-ground to  $+0.0003/-0$  diameter tolerance, and are offered in M-2 HSS in diameter increments from .010" through .375".

### Standard 2" and 2-1/2" Lengths

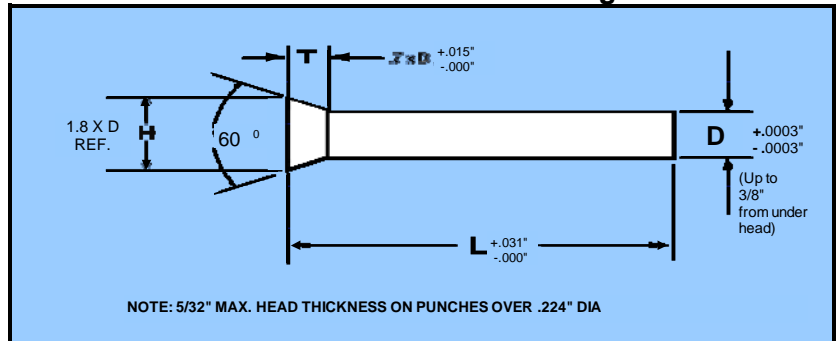

HOW TO ORDER: EXAMPLES					
QTY.	TYPE	DIA.	X	LENGTH	STEEL
100	BH	.062	X	2	TS
50	BH	.136	X	2-1/2	HSS

D STANDARD DIAMETERS .001 INCREMENTS	L LENGTHS	NET PRICE EACH PER QUANTITY (US\$)										ML MODIFY LENGTH ADD TO BASE PRICE
		TOOL STEEL					HIGH SPEED STEEL					
		100	50-99	25-49	10-24	1-9	100	50-99	25-49	10-24	1-9	
.020" - .029"	2"	0.57	0.73	0.88	1.06	1.32	0.89	0.98	1.11	1.24	1.51	PER QUOTE
	2-1/2"	0.74	0.89	1.01	1.23	1.36	0.96	1.05	1.17	1.29	1.55	
.030" - .039"	2"	0.55	0.71	0.87	1.04	1.27	0.83	0.94	1.07	1.21	1.45	\$0.20 EACH OR \$15.00 MIN.
	2-1/2"	0.71	0.86	0.98	1.20	1.34	0.90	1.01	1.13	1.27	1.53	
.040" - .0625" (1/16)	2"	0.50	0.66	0.80	0.97	1.22	0.78	0.88	1.01	1.13	1.40	
	2-1/2"	0.67	0.81	0.93	1.03	1.26	0.81	0.92	1.04	1.19	1.44	
.063" - .0781" (5/64)	2"	0.50	0.66	0.80	0.97	1.26	0.83	0.92	1.05	1.19	1.44	
	2-1/2"	0.67	0.81	0.93	1.12	1.30	0.87	0.96	1.09	1.24	1.49	
.079" - .0937" (3/32)	2"	0.50	0.66	0.80	0.97	1.30	0.89	0.98	1.11	1.24	1.51	
	2-1/2"	0.67	0.81	0.93	1.12	1.36	0.95	1.05	1.17	1.28	1.55	
.094" - .1094" (7/64)	2"	0.61	0.76	0.92	1.09	1.42	1.07	1.16	1.28	1.42	1.68	
	2-1/2"	0.79	0.96	1.10	1.28	1.52	1.11	1.21	1.34	1.47	1.73	
.110" - .125" (1/8)	2"	0.61	0.76	0.92	1.09	1.42	1.10	1.20	1.32	1.45	1.72	
	2-1/2"	0.79	0.96	1.10	1.28	1.53	1.13	1.23	1.36	1.50	1.74	
.126" .127" .128"	2"	0.75	0.89	1.06	1.23	1.56	1.30	1.40	1.53	1.68	1.93	
	2-1/2"	0.92	1.08	1.24	1.41	1.74	1.36	1.45	1.58	1.72	1.97	
⊙ .129"	2"	1.10	1.26	1.42	1.58	1.91	1.63	1.72	1.86	1.97	2.24	
	2-1/2"	1.28	1.43	1.59	1.77	2.05	1.67	1.77	1.90	2.04	2.31	
.130"	2"	0.75	0.89	1.06	1.23	1.56	1.30	1.40	1.53	1.68	1.93	
	2-1/2"	0.92	1.08	1.24	1.41	1.74	1.36	1.45	1.58	1.72	1.97	
⊙ .131" - .134"	2"	1.10	1.26	1.42	1.58	1.91	1.63	1.72	1.86	1.97	2.24	
	2-1/2"	1.28	1.43	1.59	1.77	2.05	1.67	1.77	1.90	2.04	2.31	
.135"	2"	0.75	0.89	1.06	1.23	1.56	1.30	1.40	1.53	1.68	1.93	
	2-1/2"	0.92	1.08	1.24	1.41	1.74	1.36	1.45	1.58	1.72	1.97	
⊙ .136" - .139"	2"	1.10	1.26	1.42	1.58	1.91	1.63	1.72	1.86	1.97	2.24	
	2-1/2"	1.28	1.43	1.59	1.77	2.05	1.67	1.77	1.90	2.04	2.31	
.140" .1406" (9/64)	2"	0.75	0.89	1.06	1.23	1.56	1.30	1.40	1.53	1.68	1.93	
	2-1/2"	0.92	1.08	1.24	1.41	1.75	1.36	1.45	1.58	1.72	1.97	
⊙ .141" - .156"	2"	1.10	1.26	1.42	1.58	1.91	1.63	1.72	1.86	1.97	2.24	
	2-1/2"	1.28	1.43	1.59	1.77	2.05	1.67	1.77	1.90	2.04	2.31	
.1562" (5/32)	2"	0.75	0.89	1.06	1.23	1.56	1.30	1.40	1.53	1.68	1.93	
	2-1/2"	0.92	1.08	1.24	1.41	1.74	1.36	1.45	1.58	1.72	1.97	

⊙ Denotes Form-Ground Diameters